



MEGGER® LT5 AND LT6

- **Simple to operate by just making connection and selecting the range**
- **Direct readings down to 0,01 Ω provided by 3½ digit L.C.D.**
- **Audible indication of test execution**

Digital Loop Testers

DESCRIPTION

The MEGGER® LT5 and LT6 Digital Loop Testers have been designed for quickly, accurately and reliably testing newly established and existing wiring installations. They are simple to use, both with the standard lead for socket tests and with the optional safety leads for performing tests on lighting installations and testing earth bonding.

The LT5 has two measuring ranges: 20 Ω with a resolution of 0,01 Ω and 200 Ω with a resolution of 0,1 Ω. The LT6 also has two ranges: 20 Ω with a resolution of 0,01 Ω and 2000 Ω with a resolution of 1 Ω.

Both instruments will operate on installations with a phase-to-neutral voltage 230 V a.c. ±10% and automatically compensate for supply variations. The test current, up to 25 A, is dependent on the impedance of the phase-earth loop being measured and flows for two half cycles of the supply voltage. The circuit is fuse protected and fitted with an internal thermal switch to prevent excessive heating caused by tests repeated too frequently.

Testing is very simple as there is no initial setting up to be done and no pushbutton to operate. A test is automatically executed in about 4 seconds after the selector switch is set to a measuring range and connection made to the circuit under test. (Either step may be performed first.) Neons illuminate to show that there are no open circuits in the installation wiring and that a correct

phase conductor connection exists. If the earth connection is not present, the test will not be performed.

Use of a large, 3½ digit L.C.D. makes measurement readings easy with less chance of ambiguity. It also results in a much more rugged and robust test instrument that, because of its strong plastic case, will withstand the rough treatment expected of an installation engineer's tool.

The lightweight, hand-held tester also incorporates a fold-away support stand/suspension hook for use when the operator requires both hands for using the "flying leads."

APPLICATIONS

The tests performed by the LT5 and LT6 conform not only to the requirements of Regulation 713-10-01 of the British IEE wiring regulations, but also to the European IEC and German VDE specifications.

The lower measuring range on the instruments, marked 20 Ω TN, is particularly suited to TN systems. The higher range, marked 200 Ω TT on the LT5 and 2000 Ω TT on the LT6, is more suitable to the higher impedance values found mainly in TT system installations. The LT6's 2000 Ω range is also suitable for testing the loop impedance of circuits designed to include RCDs where high loop impedances can be tolerated.

With the standard test lead, phase-earth loop impedance tests may be

performed at installation socket outlets. The "flying lead" only requires two connections, has two fused prod terminations and allows various other loop tests to be performed easily and conveniently. These tests include:

- Phase-to-earth and phase-to-neutral loop tests on both single- and three-phase installations.
- Loop tests on fittings in a lighting installation
- Loop tests on bonded metal work (an alternative lead set is also available especially for this work.)
- Phase-to-neutral tests to provide data for assessment of prospective short-circuit current of an installation (as required by IEE Regulations 313-01-01 and 434-02-01)

FEATURES AND BENEFITS

- Simple to operate by just making connection and selecting the range
- Direct readings down to 0,01 Ω provided by 3½ digit L.C.D.
- Tests conform to IEE wiring regulations, and to European IEC and VDE specifications
- Neon indication of earth continuity and correct phase connection
- Audible indication of test execution
- Fuse and thermal protection
- Optional two wire safety "flying leads" for work on light fittings and earth bonding
- Phase-neutral tests to assist determination of psc

SPECIFICATIONS

Ranges

LT5

20 Ω TN: 0,01 to 19,99 Ω
200 Ω TT: 0,1 to 199,9 Ω

LT6

20 Ω TN: 0,01 to 19,99 Ω
2000 Ω TT: 1 to 1999 Ω

Accuracy (at 23° C ±2° C)

LT5

20 Ω TN Range: ±2% of reading
±3 digits
200 Ω TT Range: ±2% of reading
±1 digit

LT6

20 Ω TN Range: ±2% of reading
±3 digits
2000 Ω TT Range: ±3% of reading
±1 digit

Display

3½ digit L.C.D. (max. reading 1999)

Operational Voltage

230 V a.c. r.m.s. ±10%, 45 to 65 Hz
(from the mains supply of the circuit under test)

Temperature Coefficient

Within twice stated accuracy over the operating temperature range

Temperature Range

Operation: -5 to +50°C

Storage: -20 to +60°C

Humidity Range

Operation: 80% RH at 40°C max.

Storage: 93% RH at 40°C max.

Overload Range

Will withstand transients of up to 600 V. Thermal cutout protection to prevent overheating caused by excessive repetition of tests

Interference Rejection

10 V d.c. max.

E.M.C.

The instrument meets EN 50081-1 and EN 50082-1 (1992)

Fuses

13 A, 250 V ceramic fuse, 25 x 6 mm (to BS 1362) fitted in BS 1363 plug

7A, 440 V ceramic fuse, 32 x 6 mm (to DEF 63A, max. prospective overload 33 kA) fitted into instrument. Also fitted in "flying lead" (safety dual test lead) and earth bond test lead

Safety

The instrument meets the requirements for double insulation to IEC 1010-1 (1992) at 230 V installation category II with mains power cord and plug, and at 230 V installation category III with fused test leads.

Using the Safety Dual Test Lead

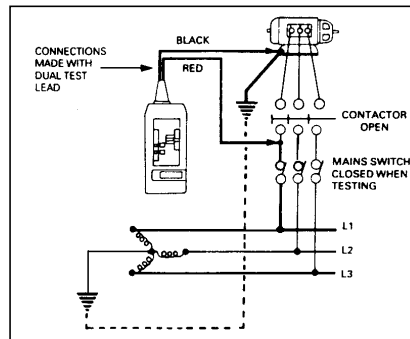

Testing the earth-fault loop impedance of three-phase equipment

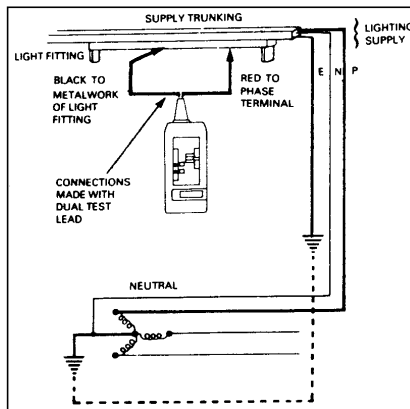

Testing the earth connection of a light fitting

Dimensions (not including test lead)

195 H x 90 W x 40 D mm

7,5 H x 3,5 W x 1,6 D in.

Weight

350 g (0,75 lb approx)

Testing at a Socket Outlet with the Standard Lead

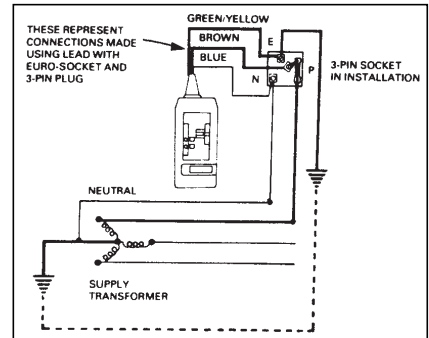

Testing the earth-fault loop impedance at a three-pin socket

Phase-Neutral Loop Testing

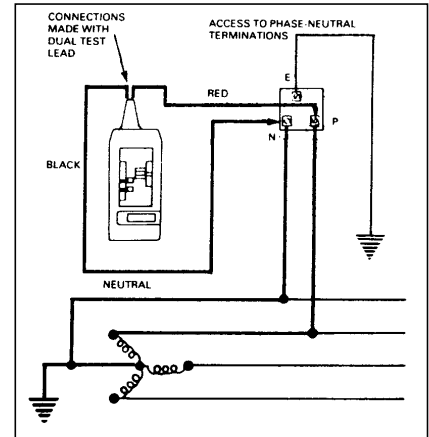

ORDERING INFORMATION

Item (Qty.)	Order Code	Optional Accessories	Order Code
Digital Loop Tester	LT5	Safety dual test lead with Euro-socket and fused prod	6280-294
Digital Loop Tester	LT6	Safety earth bond test lead with fused prod and BS 1363 plug	6220-344
Included Accessories		Safety earth bond test lead with fused prod and CEE 7/7 plug	6220-565
Mains supply lead fitted with Euro-socket and three-pin plug (to BS 1363 for U.K.)	6131-970	Test-and-carry case	6420-040
OR		GS38 red probe	8100-754
Mains supply lead fitted with CEE 7/7 plug (LT5/D2)	6280-197	Crocodile clip, red, for use with safety dual test lead	8100-870
Operating instruction book	6172-063	Crocodile clip, black, for use with safety dual test lead	8100-871
Zip-up carry case	6420-078		